

IRB 1600

The highest performance 10 kg robot.

Performance is often a trade off, optimizing for speed or accuracy. With ABB's IRB 1600, you don't have to choose. The robot's cycle times are shorter, sometimes half that of other robots, allowing you to increase throughput. Meanwhile, you will enjoy the work piece quality that only an ABB robot can offer. Extra everything.



Double your throughput

The IRB 1600 has up to 50 percent shorter cycle times than competing robots in material handling, machine tending and process applications. It speeds up and slows down faster than other robots, saving time while moving between tasks. This is possible due to ABB's patented second generation QuickMove motion control, combined with the robot's strong motors and low friction losses in the spur gears.

No more cutting corners

At high speed, most robots will cut corners. With the IRB 1600, the path will be the same regardless of speed, thanks to the robot's unique combination of brains and brawn. Intelligent second generation TrueMove motion control means that "what-you-program-is-what-you-get". Add muscle – a heavy and stiff design – low vibrations and low friction – and you have a robot that will deliver consistently high work piece quality, high yield and few rejects.

Outstanding reliability

The IRB 1600 offers outstanding reliability, even in the toughest environments and the most demanding 24/7 duty cycles. The entire manipulator is IP 54 classed and sensitive parts are IP 67 classed as standard. The optional protection Foundry Plus offers IP 67, special paint, rust protection and is tailor made for tough foundry environments. The rigid and heavy design combined with spur gears, make the robot extremely robust. Smart collision detection software further adds to the robot's outstanding reliability.

Easy to integrate

Mounting is fully flexible: on a shelf, on the wall, tilted or inverted. By choosing the compact short-arm version with the 1.2 m reach, you can even fit the IRB 1600 inside a machine, while ensuring sufficient payload as the maximum total load is as high as 36 kg.

Sustainable and healthy

Low friction spur gears, and no unnecessary moves due to QuickMove and TrueMove, reduces power consumption down to 0.58 kW at max speed, and even less at low speeds. The airborne noise level of just <70 dB (A) secures a healthy sound environment.

IRB 1600

Main applications

Machine tending, material handling, arc welding, cutting, dispensing, assembly, palletizing and packaging, measuring, die casting, injection moulding

Specification

Variants	Reach(m)	Payload(kg)	Armload(kg)
IRB 1600-6/1.2	1.2	6	30,5
IRB 1600-6/1.45	1.45	6	30,5
IRB 1600-10/1.2	1.2	10	20,5
IRB 1600-10/1.45	1.45	10	20,5
Number of axes	6+3 external (up to 36 with MultiMove)		
Protection	Standard IP54; opt. FoundryPlus 2 (IP 67)		
Mounting	Floor, wall, shelf, tilted, inverted		
IRC5 Controller variants	Single cabinet, Dual cabinet, Compact		

Physical

Dimensions robot base:	484 x 648
Robot height: IRB 1600-6/1.2 and IRB 1600-10/1.2	1069 mm
Robot height: IRB 1600-6/1.45 and IRB 1600-10/1.45	1294 mm
Robot weight:	250 kg

Performance (according to ISO 9283)

	6/1.2	6/1.45	10/1.2	10/1.45
Pos. repeatability (RP)	0.02 mm	0.02 mm	0.02 mm	0.05 mm
Path repeatability (RT)	0.13 mm	0.19 mm	0.06 mm	0.13 mm

Movement

Working range	1.2	1.45
Axis 1	+180° to -180°	+180° to -180°
Axis 2	+136° to -63°	+150° to -90°
Axis 3	+55° to -235°	+65° to -245°
Axis 4	+200° to -200° def. +/-190° revolution	+200° to -200° def. +/-190° revolution
Axis 5	+115° to -115°	+115° to -115°
Axis 6	+400° to -400° def. +/-288 revolution	+400° to -400° def. +/-288 revolution
Maximum Speed	6 kg	10 kg
Axis 1	150°/s	180°/s
Axis 2	160°/s	180°/s
Axis 3	170°/s	185°/s
Axis 4	320°/s	385°/s
Axis 5	400°/s	400°/s
Axis 6	460°/s	460°/s

Electrical connections

Supply voltage	200-600 V, 50-60 Hz
Power consumption	ISO-Cube at max speed 0.58 kW

Environment

Ambient temperature for mechanical unit:	
During operation	+ 5°C (41°F) to + 45°C (113°F)
During transportation and storage	- 25°C (- 13°F) to + 55°C (131°F)
For short periods (max 24h)	up to + 70°C (158°F)
Relative humidity	Max. 95% at constant temperature
Safety	Double circuits with supervisions, emergency stops and safety functions, 3-position enable device
Emission	EMC/EMI shielded

Data and dimensions may be changed without notice

Working range

IRB 1600-x/1.2

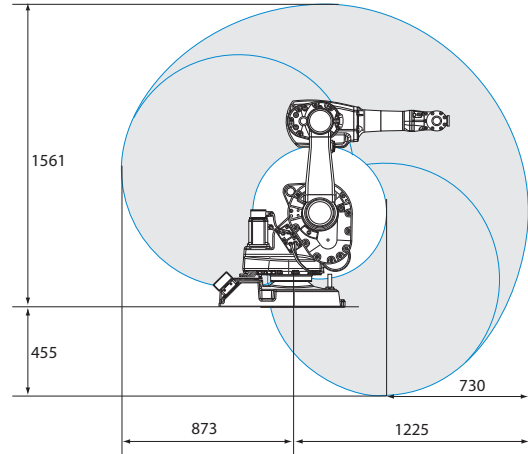

IRB 1600-x/1.45

